

MOUNTING INFORMATION (LOOKING AT WALL "THROUGH" FIXTURE)

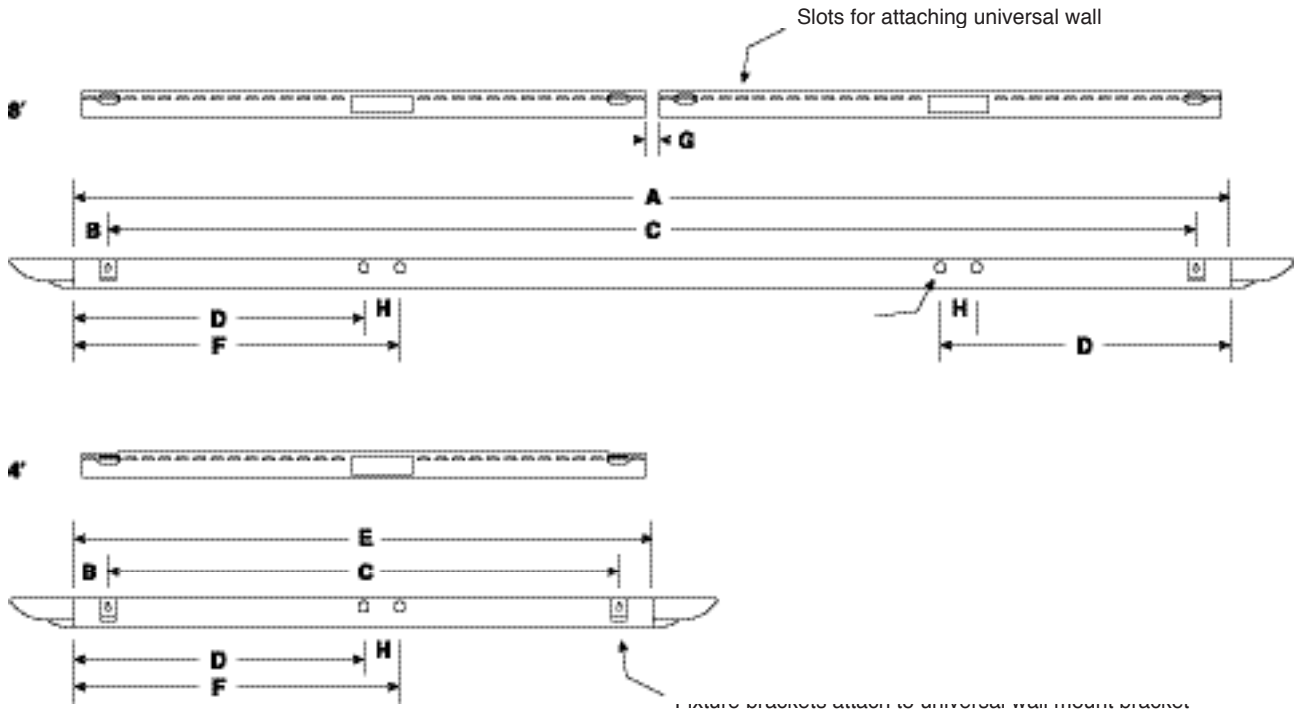

DATA CHART

Nominal Length	Approx. Weight 1-lamp	A*	B	C	D	E	F	G	H
4'	8 lbs.	—	2 <sup>13</sup> / <sub>16</sub> "	42 <sup>1</sup> / <sub>2</sub> "	24 <sup>1</sup> / <sub>16</sub> "	48 <sup>1</sup> / <sub>8</sub> "	27 <sup>1</sup> / <sub>16</sub> "	—	3"
8'	16 lbs.	96 <sup>1</sup> / <sub>16</sub> "	2 <sup>13</sup> / <sub>16</sub> "	90 <sup>7</sup> / <sub>16</sub> "	24 <sup>1</sup> / <sub>16</sub> "	—	27 <sup>1</sup> / <sub>16</sub> "	1 <sup>9</sup> / <sub>32</sub> "	3"

Note: Fixtures mounted in rows require two mounting locations per fixture.  
 \*Standard end-of-row end caps add 5/8" to the overall row length.

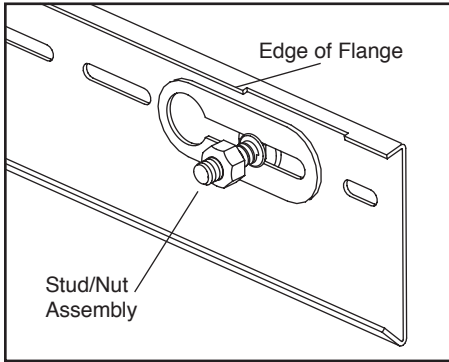

**Step 1**  
Using mounting information and data chart from previous page, install bracket to wall using continuous slots. Ensure bracket is level. Insert stud/nut assembly into hole on embossed slots of mounting bracket and slide to edge of flange.

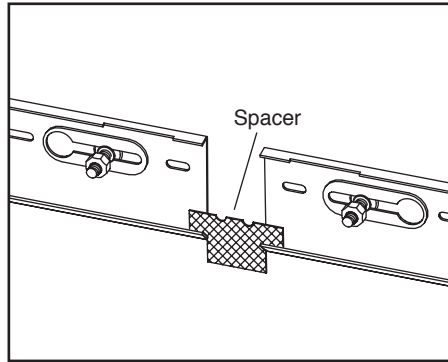

**Step 2**  
Place spacer into v-groove to align and install next wall bracket. Continue mounting brackets until row is complete.

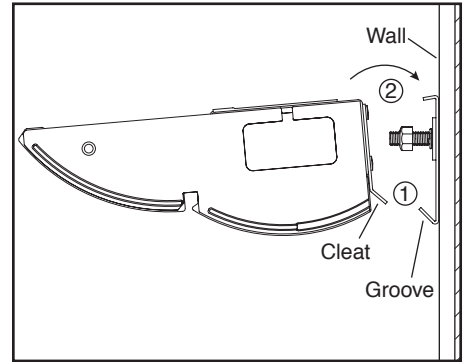

**Step 3**  
Remove ballast cover on fixture. Slip cleat into lower v-groove on mounting bracket (1) and push stud through keyhole slot (2).

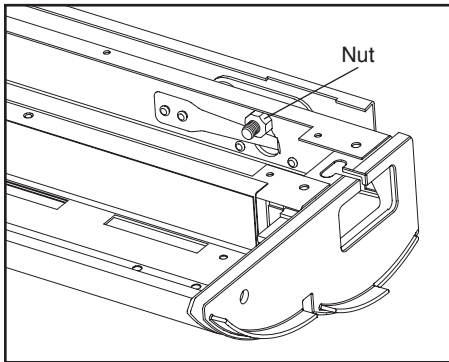

**Step 4**  
Level fixtures by adjusting nut on stud at each end of fixture.

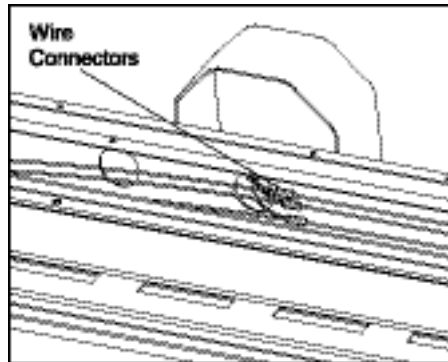

**Step 5**  
Pull wires from J-box into fixture housing and splice to harness as required.

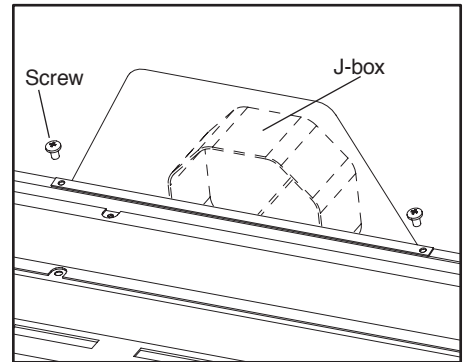

**Step 6**  
Install J-box cover to mounting bracket with screws as required.

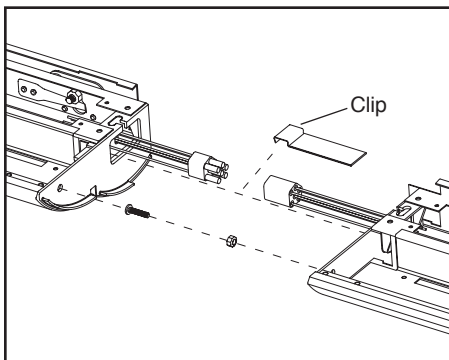

**Step 7**  
Repeat step 3 for next fixture. Connect harness plugs together. Slide fixture to mate with previous fixture in row. Secure fixtures using supplied nut and bolt. Snap wire channel clip on bottom edge of wireway as shown.

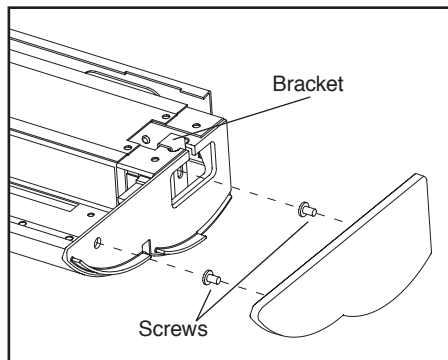

**Step 8**  
When all fixtures in row have been installed and leveled, slide bracket into internal end cap as shown. Attach and align external end cap with screws provided. Replace all ballast covers.