



FEATURES

- Rectilinear wall mount
- Up to three T8, T5, or T5HO lamps in cross section
- Direct/Indirect distribution
- Heavy 20-gauge steel
- Symmetric distribution
- Controls compatible
- Attractive cable/bracket support mount
- Wide selection of flush or regressed shielding media
- Decorative perforated, slotted, or patterned strips on either side of shielding for added visual interest
- Integral small case ballasting
- Control compatible for daylight harvesting, occupancy sensors, or dimming
- Low profile, adjustable cable mount hanging system
- Office and school applications

SHAPE AND DIMENSIONS



PROJECT INFORMATION

Project Name	Type
Catalog No.	Date

CONSTRUCTION

- Housing lengths of 4', 8', or 12' lengths
- Mounting points maintain convenient, predictable locations.
- The exact shape of the housing is maintained by the use of a patented inner die cast plate at each fixture end (Patent# 6,796,676 B2) throughout the run to prevent snaking. The housing is designed to wrap around the plate and secures on top with concealed screws to ensure housing tolerances are consistent.

FINISH

Housing and all painted parts are treated with a multi-stage phosphate prior to finish. Parts are then finished with a white powder coat for maximum consistent coverage and longevity. Other colors may be specified; refer to page MTX-1 or contact your local Alera Lighting representative.

SHIELDING

Plank Wall Mount includes both direct and indirect lighting elements. Shielding for the direct element may be selected as a:

- White cross baffle (WCB),
- Regressed perforated panel (RPF)
- Flat perforated panel (FPF)
- Opal acrylic (OA)
- Acrylic pattern 12 (A12)

MOUNTING

Plank Wall Mount is designed for wall mount applications using wall brackets. Brackets are universal and secure to the die cast end plates using a screw connection. Aircraft cable support may be used in addition to the wall bracket mounting if desired for aesthetic and/or additional load carrying capacity. Electrical connections are made from a standard 2" x 4" j-box; j-box and j-box covers by others.

LABELS AND ELECTRICAL

- UL 1598 or CSA
- Prewired w/ T8, T5, or T5HO electronic ballasts
- Quick connect plugs standard
- Damp label on most models

Name:	PLK-2T8-PERF-WCB-E
Test #:	13890
Efficiency:	92%
LER:	80

ORDERING INFORMATION

EXAMPLE: PLK-16-1T5-WM-WCB-EU-MW

PLK -									
MODEL		HOUSING TYPE		SHIELDING		VOLTAGE		FINISH	
PLK Plank		Blank Solid (Std.)		WCB White Cross Baffle ¹		U 120V-277V		MW Matte White (Std.)	
		PFST Perforated Strip		RPF Regressed Perforated		120 120V		ZT ZET Metallic Silver	
		HSLT Horizontal Slot Strip		FPF Flat Perforated		277 277V		See MTX-1 for other color selections.	
		VSLT Vertical Slot Strip		OA Opal Acrylic Lens		347 347V			
				A12 Pattern 12 .125" Thick Acrylic Lens					
ROW LENGTH	LAMP TYPE AND PROFILE	MOUNTING METHOD		BALLAST		OPTIONS			
4 4' Single	1T5 One T5 Lamp	WM Wall Mount		E Electronic, Instant Start (Std. for T8)		DC Dust Cover (T8 only)		LR Left/Right Switching (2-Lamp only)	
8 8' Single	2T5 Two T5 Lamps	WMC Wall Mount with Cable		EP Electronic, Programmed Start (Std. for T5 & T5HO, optional for T8)		IBOB Inboard/Outboard Switching (3-Lamp only)		EL One Emergency Battery Pack ^{2,3}	
12 12' Single	3T5 Three T5 Lamps			ED Electronic, Dimming (Must specify)		EMC One Emergency Circuit ^{2,3,4}		NL Night Light Circuit ^{2,3,4}	
– Indicate row length over 8' in 4' increments	1T5HO One T5HO Lamp			ESD Electronic, Step Dimming		GLR Fast Blow Fuse		GMF Slow Blow Fuse	
	2T5HO Two T5HO Lamps			Unless specified, Alera will use fewest ballasts possible.		CSA UL listed or CSA certified for Canada		DL Damp Label (Available on most models)	
	3T5HO Three T5HO Lamps								
	1T8 One T8 Lamp								
	2T8 Two T8 Lamps								
	3T8 Three T8 Lamps								

¹ Includes .020 thick white overlay.

² Specify voltage. For additional, specify quantity before nomenclature (Example: 2EL120, EMC277).

³ Not available with all configurations; some limitations apply. Contact factory for details.

⁴ One extra feed drop per row with through wiring. (Standard is one 4ft lamp per circuit.)

Protected by US Patent 6,796,676.

Protected by Canada Patent 2,450,528.

Specifications subject to change without notice.

Page 1/4 Rev. 01/19/11

BEAMS / PLK WM

CROSS SECTION

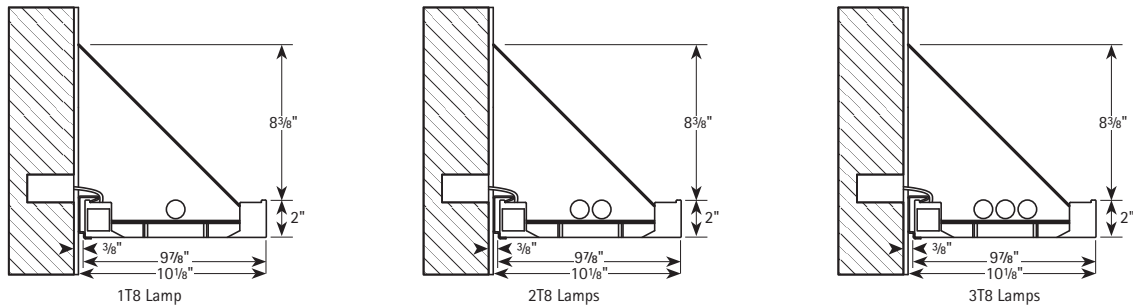

PHOTOMETRIC DATA

LUMINAIRE DATA Test 14038

Luminaire	PLK-1T8-WCB-E
	Plank Architectural Beam
	9.75 x 48 1-Lamp with Gloss White Cross Baffle and Opal Overlay
Ballast	REL-1P32-SC
Ballast Factor	0.92
Lamp	F32T8
Lumens per Lamp	2900
Watts	34
Shielding Angle	0° = 90 90° = 90
Spacing Criterion	0° = 1.03 90° = 1.25
Luminous Opening in Feet	Length: 3.67 Width: 0.25 Height: 0.00

AVG. LUMINANCE (Candela/Sq. M.)

Angle	0.0	22.5	45.0	67.5	90.0
0	3344	3344	3344	3344	3344
30	2587	2642	2831	3089	3265
40	2205	2297	2542	2894	3155
45	1974	2074	2373	2771	3069
50	1697	1843	2190	2628	2957
55	1493	1554	1964	2434	2741
60	1408	1455	1713	2135	2276
65	1332	1360	1555	1638	1555
70	1269	1269	1441	1338	1166
75	1224	1269	1315	1179	1133
80	1216	1216	1216	1013	946
85	1212	1077	808	673	673

COEFFICIENTS OF UTILIZATION (%)

RCR	80					70					50					0				
	RW	70	50	30	10	70	50	30	10	50	30	10	50	30	10	0	0	0		
1	89	85	81	78	78	75	72	70	58	56	54	18	16	16	16	16	16			
2	81	74	69	64	71	66	61	57	51	48	45	18	16	16	16	16	16			
3	74	65	59	53	65	58	53	48	45	41	38	14	14	14	14	14	14			
4	67	58	51	45	60	51	45	41	40	36	32	12	12	12	12	12	12			
5	62	51	44	38	55	46	40	35	35	31	28	10	10	10	10	10	10			
6	57	46	38	33	50	41	35	30	32	27	24	9	9	9	9	9	9			
7	52	41	34	29	46	37	31	26	29	24	21	8	8	8	8	8	8			
8	48	37	30	25	43	33	27	23	26	22	19	7	7	7	7	7	7			
9	45	34	27	22	40	30	24	20	24	20	17	7	7	7	7	7	7			
10	42	31	24	20	37	28	22	18	22	18	15	6	6	6	6	6	6			

INDOOR CANDELA PLOT

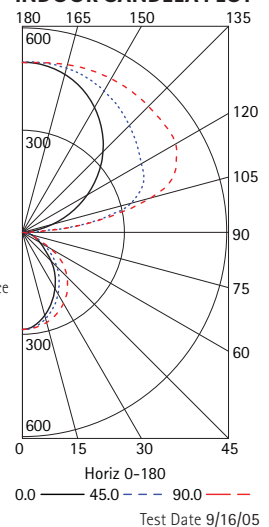

ZONAL LUMEN SUMMARY

Zone	Lumens	% Lamp	% Fixt.
0-30	207	7.1	7.4
0-40	327	11.3	11.7
0-60	529	18.2	18.9
0-90	620	21.4	22.1
90-120	774	26.7	27.7
90-130	1138	39.2	40.6
90-150	1767	60.9	63.1
90-180	2179	75.1	77.9
0-180	2799	96.5	100.0

RCR = Room Cavity Ratio

RC = Effective Ceiling Cavity Reflectance RW = Wall Reflectance

ENERGY DATA

Total Luminaire Efficiency	96.5%
Luminaire Efficacy Rating (LER)	76
ANSI/IESNA RP-1-2004 Compliance	Yes-VDT Intensive Use
Comparative Yearly Lighting Energy Cost per 1000 Lumens	\$3.16 based on 3000 hrs. and \$0.08 per KWH

PHOTOMETRIC DATA

LUMINAIRE DATA Test 14014

Luminaire	PLK-2T8-WCB-E
	Plank Architectural Beam
	9.75 x 48 2-Lamp with Gloss White Center Louver and Side Reflectors
Ballast	REL-2P32-SC
Ballast Factor	0.88
Lamp	F32T8
Lumens per Lamp	2900
Watts	63
Shielding Angle	0° = 90 90° = 90
Spacing Criterion	0° = 1.03 90° = 1.23
Luminous Opening in Feet	Length: 3.67 Width: 0.25 Height: 0.00

AVG. LUMINANCE (Candela/Sq. M.)

Angle	0.0	22.5	45.0	67.5	90.0
0	8095	8095	8095	8095	8095
30	6259	6435	6882	7451	7762
40	5314	5544	6126	6876	7366
45	4745	5011	5691	6504	7051
50	4107	4435	5183	6059	6662
55	3579	3784	4643	5543	6095
60	3402	3473	4059	4974	5467
65	3220	3276	3692	4331	4608
70	3053	3121	3499	3636	3567
75	2992	3128	3309	3309	3264
80	3040	3175	3243	3243	3243
85	3365	3365	3365	3231	3231

COEFFICIENTS OF UTILIZATION (%)

RCR	80					70					50					0				
	RW	70	50	30	10	70	50	30	10	50	30	10	50	30	10	0	0	0		
1	90	86	82	79	80	77	74	71	60	58	56	22	22	22	22	22	22	22		
2	82	75	70	65	73	67	63	59	53	49	47	19	19	19	19	19	19	19		
3	75	66	59	54	67	59	54	49	47	43	39	16	16	16	16	16	16	16		
4	68	59	51	46	61	53	46	42	41	37	34	14	14	14	14	14	14	14		
5	63	52	45	39	56	47	41	36	37	33	29	12	12	12	12	12	12	12		
6	58	47	39	34	51	42	36	31	33	29	25	11	11	11	11	11	11	11		
7	53	42	35	30	48	38	32	27	30	26	22	10	10	10	10	10	10	10		
8	49	38	31	26	44	34	28	24	27	23	20	9	9	9	9	9	9	9		
9	46	35	28	23	41	31	25	21	25	21	17	8	8	8	8	8	8	8		
10	43	32	25	20	38	29	23	19	23	19	16	7	7	7	7	7	7	7		

INDOOR CANDELA PLOT

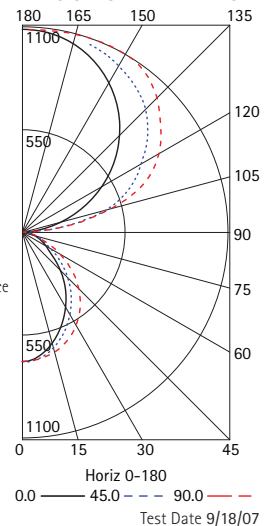

ZONAL LUMEN SUMMARY

Zone	Lumens	% Lamp	% Fixt.
0-30	502	8.7	8.9
0-40	790	13.6	14.1
0-60	1266	21.8	22.6
0-90	1506	26.0	26.8
90-120	1211	20.9	21.6
90-130	1907	32.9	34.0
90-150	3221	55.5	57.4
90-180	4108	70.8	73.2
0-180	5613	96.8	100.0

RCR = Room Cavity Ratio

RC = Effective Ceiling Cavity Reflectance RW = Wall Reflectance

ENERGY DATA

Total Luminaire Efficiency	96.8%
Luminaire Efficacy Rating (LER)	78
ANSI/IESNA RP-1-2004 Compliance	Yes-VDT Intensive Use
Comparative Yearly Lighting Energy Cost per 1000 Lumens	\$3.08 based on 3000 hrs. and \$0.08 per KWH

PHOTOMETRIC DATA

LUMINAIRE DATA Test 14017

Luminaire	PLK-3T8-WCB-E
	Plank Architectural Beam
	9.75 x 48 3-Lamp with Gloss White Center Louver and Side Reflectors
Ballast	REL-3P32-SC
Ballast Factor	0.88
Lamp	F32T8
Lumens per Lamp	2900
Watts	88
Shielding Angle	0° = 90 90° = 90
Spacing Criterion	0° = 1.02 90° = 1.17
Luminous Opening in Feet	Length: 3.67 Width: 0.25
	Height: 0.00

AVG. LUMINANCE (Candela/Sq. M.)

Angle	0.0	22.5	45.0	67.5	90.0
0	12424	12424	12424	12424	12424
30	9523	9632	10079	10770	11230
40	8071	8239	8852	9801	10537
45	7201	7433	8179	9291	10187
50	6187	6516	7447	8797	9819
55	5420	5584	6668	8243	9368
60	5092	5162	5889	7579	8799
65	4802	4830	5385	6829	7967
70	4494	4528	5077	5934	6860
75	4306	4442	4669	5031	5394
80	4256	4256	4459	4662	
85	4308	3904	3500	3500	3500

COEFFICIENTS OF UTILIZATION (%)

RCR	80			70			50			0		
	RW	70	50	30	10	70	50	30	10	50	30	10
1	86	82	79	76	77	73	71	68	57	56	54	22
2	78	72	66	62	70	64	60	56	51	48	45	19
3	71	63	57	52	64	57	51	47	45	41	38	16
4	65	56	49	44	58	50	45	40	40	36	32	14
5	60	50	43	38	53	45	39	34	36	31	28	12
6	55	45	38	32	49	40	34	30	32	28	24	11
7	51	40	33	28	45	36	30	26	29	25	21	10
8	47	36	30	25	42	33	27	23	26	22	19	9
9	44	33	27	22	39	30	24	20	24	20	17	8
10	41	30	24	20	37	27	22	18	22	18	15	7

INDOOR CANDELA PLOT

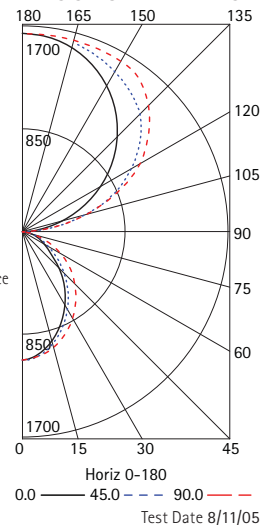

ZONAL LUMEN SUMMARY

Zone	Lumens	% Lamp	% Fixt.
0-30	752	8.6	9.4
0-40	1173	13.5	14.6
0-60	1871	21.5	23.3
0-90	2224	25.6	27.7
90-120	1518	17.4	18.9
90-130	2517	28.9	31.4
90-150	4463	51.3	55.7
90-180	5794	66.6	72.3
0-180	8018	92.2	100.0

RCR = Room Cavity Ratio

RC = Effective Ceiling Cavity Reflectance RW = Wall Reflectance

ENERGY DATA

Total Luminaire Efficiency	92.2%
Luminaire Efficacy Rating (LER)	80
ANSI/IESNA RP-1-2004 Compliance	Yes-VDT Normal Use
Comparative Yearly Lighting Energy Cost per 1000 Lumens	\$3.00 based on 3000 hrs. and \$0.08 per KWH

PHOTOMETRIC DATA

LUMINAIRE DATA Test 14020

Luminaire	PLK-1T5HO-WCB-EP
	Plank Architectural Beam
	9.75 x 48 1-Lamp with Gloss White Center Louver and Opal Overlay
Ballast	ICN2S5490C
Ballast Factor	1.02
Lamp	F54T5HO
Lumens per Lamp	4450
Watts	62
Shielding Angle	0° = 90 90° = 90
Spacing Criterion	0° = 1.03 90° = 1.25
Luminous Opening in Feet	Length: 3.67 Width: 0.25
	Height: 0.00

AVG. LUMINANCE (Candela/Sq. M.)

Angle	0.0	22.5	45.0	67.5	90.0
0	4540	4540	4540	4540	4540
30	3509	3603	3888	4240	4430
40	2971	3124	3492	3967	4242
45	2671	2837	3252	3750	4048
50	2318	2519	2975	3504	3778
55	2045	2168	2679	3129	3334
60	1924	1994	2370	2651	2745
65	1832	1888	2165	2249	2221
70	1749	1818	2024	1989	1887
75	1677	1813	1904	1904	1813
80	1757	1757	1824	1757	1757
85	1750	1615	1615	1481	1481

COEFFICIENTS OF UTILIZATION (%)

RCR	80			70			50			0		
	RW	70	50	30	10	70	50	30	10	50	30	10
1	88	84	80	77	77	74	71	69	56	54	53	16
2	80	73	68	63	70	65	60	57	49	46	44	14
3	73	64	58	53	64	57	52	47	44	40	37	12
4	67	57	50	44	59	51	45	40	39	35	31	10
5	61	51	43	38	54	45	39	34	35	30	27	9
6	56	45	38	33	49	40	34	30	31	27	23	8
7	52	41	33	28	46	36	30	26	28	24	20	7
8	48	37	30	25	42	33	27	23	25	21	18	7
9	44	33	27	22	39	30	24	20	23	19	16	6
10	41	30	24	20	37	27	22	18	21	17	14	5

INDOOR CANDELA PLOT

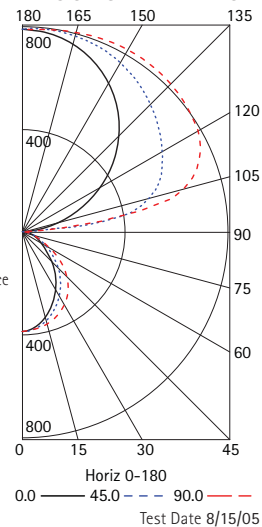

ZONAL LUMEN SUMMARY

Zone	Lumens	% Lamp	% Fixt.
0-30	282	6.3	6.6
0-40	446	10.0	10.4
0-60	716	16.1	16.7
0-90	847	19.0	19.8
90-120	1225	27.5	28.6
90-130	1793	40.3	41.9
90-150	2785	62.6	65.0
90-180	3434	77.2	80.2
0-180	4281	96.2	100.0

RCR = Room Cavity Ratio

RC = Effective Ceiling Cavity Reflectance RW = Wall Reflectance

ENERGY DATA

Total Luminaire Efficiency	96.2%
Luminaire Efficacy Rating (LER)	70
ANSI/IESNA RP-1-2004 Compliance	Yes-VDT Intensive Use
Comparative Yearly Lighting Energy Cost per 1000 Lumens	\$3.43 based on 3000 hrs. and \$0.08 per KWH

PHOTOMETRIC DATA

LUMINAIRE DATA Test 14021

Luminaire	PLK-2T5HO-WCB-EP
	Plank Architectural Beam
	9.75 x 48 2-Lamp with Gloss White Center Louver and Opal Overlay
Ballast	ICN2S5490C
Ballast Factor	1.00
Lamp	F54T5HO
Lumens per Lamp	4450
Watts	121
Shielding Angle	0° = 90 90° = 90
Spacing Criterion	0° = 1.02 90° = 1.21
Luminous Opening in Feet	Length: 3.67 Width: 0.25 Height: 0.00

AVG. LUMINANCE (Candela/Sq. M.)

Angle	0.0	22.5	45.0	67.5	90.0
0	9890	9890	9890	9890	9890
30	7573	7749	8263	8900	9279
40	6417	6647	7275	8071	8592
45	5724	6023	6686	7549	8179
50	4964	5275	6078	7063	7720
55	4377	4541	5400	6484	7220
60	4153	4200	4834	5913	6617
65	3942	3970	4469	5274	5746
70	3739	3773	4288	4494	4596
75	3626	3717	3944	4034	4125
80	3716	3581	3783	3716	3783
85	3904	3231	3096	2692	2827

COEFFICIENTS OF UTILIZATION (%)

RC	80					70					50					0
RW	70	50	30	10	70	50	30	10	50	30	10	50	30	10	0	
1	86	82	79	76	76	73	70	68	56	54	52	17				
2	78	72	67	62	69	64	60	56	49	46	43	15				
3	72	63	57	52	63	56	51	47	43	40	37	13				
4	66	56	49	44	58	50	44	39	38	34	31	11				
5	60	50	43	37	53	44	38	34	34	30	27	10				
6	55	45	37	32	49	40	34	29	31	27	23	9				
7	51	40	33	28	45	36	30	25	28	24	20	8				
8	47	36	29	25	42	32	27	22	25	21	18	7				
9	44	33	26	22	39	30	24	20	23	19	16	6				
10	41	30	24	19	36	27	21	18	21	17	14	6				

INDOOR CANDELA PLOT

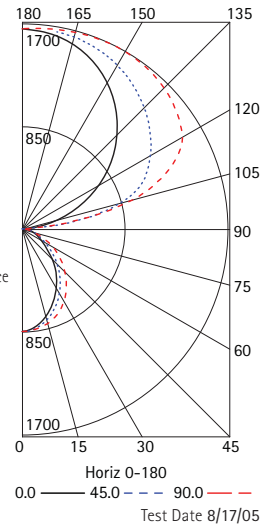

ZONAL LUMEN SUMMARY

Zone	Lumens	% Lamp	% Fixt.
0-30	608	6.8	7.3
0-40	952	10.7	11.4
0-60	1514	17.0	18.1
0-90	1798	20.2	21.5
90-120	2078	23.4	24.8
90-130	3203	36.0	38.3
90-150	5222	58.7	62.4
90-180	6569	73.8	78.5
0-180	8366	94.0	100.0

RCR = Room Cavity Ratio

RC = Effective Ceiling Cavity Reflectance RW = Wall Reflectance

ENERGY DATA

Total Luminaire Efficiency	94.0%
Luminaire Efficacy Rating (LER)	69
ANSI/IESNA RP-1-2004 Compliance	Yes-VDT Normal Use
Comparative Yearly Lighting Energy Cost per 1000 Lumens	\$3.48 based on 3000 hrs. and \$0.08 per KWH

PHOTOMETRIC DATA

LUMINAIRE DATA Test 14024

Luminaire	PLK-3T5HO-WCB-EP
	Plank Architectural Beam
	9.75 x 48 3-Lamp with Gloss White Center Louver and Opal Overlay
Ballast	ICN-4S5490C-2LS
Ballast Factor	1.00
Lamp	F54T5HO
Lumens per Lamp	4450
Watts	183
Shielding Angle	0° = 90 90° = 90
Spacing Criterion	0° = 1.02 90° = 1.16
Luminous Opening in Feet	Length: 3.67 Width: 0.25 Height: 0.00

AVG. LUMINANCE (Candela/Sq. M.)

Angle	0.0	22.5	45.0	67.5	90.0
0	16049	16049	16049	16049	16049
30	12260	12409	13005	13736	14400
40	10368	10583	11425	12558	13554
45	9225	9540	10585	11879	13074
50	7958	8396	9673	11225	12557
55	6995	7220	8693	10431	11863
60	6617	6711	7743	9479	10864
65	6274	6302	7162	8467	9716
70	5900	5900	6757	7306	8198
75	5757	5893	6255	6391	6845
80	5810	5743	5945	5608	5878
85	5923	5115	4846	4577	4308

COEFFICIENTS OF UTILIZATION (%)

RC	80					70					50					0
RW	70	50	30	10	70	50	30	10	50	30	10	50	30	10	0	
1	84	80	77	74	74	71	68	66	55	53	51	18				
2	76	70	65	60	68	62	58	54	48	45	43	16				
3	70	62	55	50	62	55	50	45	43	39	36	13				
4	64	54	48	43	56	49	43	39	38	34	31	12				
5	58	48	41	36	52	43	37	33	34	30	26	10				
6	54	43	36	31	48	39	33	29	30	26	23	9				
7	50	39	32	27	44	35	29	25	27	23	20	8				
8	46	35	29	24	41	32	26	22	25	21	18	7				
9	43	32	26	21	38	29	23	19	23	19	16	7				
10	40	29	23	19	35	26	21	17	21	17	14	6				

INDOOR CANDELA PLOT

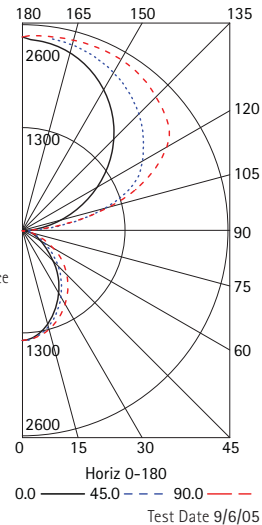

ZONAL LUMEN SUMMARY

Zone	Lumens	% Lamp	% Fixt.
0-30	968	7.3	8.0
0-40	1510	11.3	12.5
0-60	2405	18.0	19.8
0-90	2861	21.4	23.6
90-120	2725	20.4	22.5
90-130	4341	32.5	35.8
90-150	7284	54.8	60.1
90-180	9259	69.4	76.4
0-180	12120	90.8	100.0

RCR = Room Cavity Ratio

RC = Effective Ceiling Cavity Reflectance RW = Wall Reflectance

ENERGY DATA

Total Luminaire Efficiency	90.8%
Luminaire Efficacy Rating (LER)	66
ANSI/IESNA RP-1-2004 Compliance	Noncompliant
Comparative Yearly Lighting Energy Cost per 1000 Lumens	\$3.64 based on 3000 hrs. and \$0.08 per KWH